

JA-110P Bus PIR motion detector

The JA-110P product is a component of the JABLOTRON 100 system. It serves for the detection of human movement in building interiors. Its detection characteristics can be modified by using an alternative lens. False alarm immunity is available in two options. The detector has a pulse reaction (only reports its triggering). The detector should be installed by a trained technician with a valid certificate issued by an authorized distributor.

Installation

The detector can be installed onto a wall or in the corner of the room. There should be no objects which quickly change temperature (electric heaters, gas appliances, etc.) or which move (e.g. curtains hanging above a radiator) or pets in the detector's field of sight. It is not recommended to install the detector opposite windows or floodlights or in places with over-intense air circulation (close to ventilators, heat sources, air conditioning outlets, unsealed doors, etc.). There should be no obstacles in front of the detector which might obstruct its view.

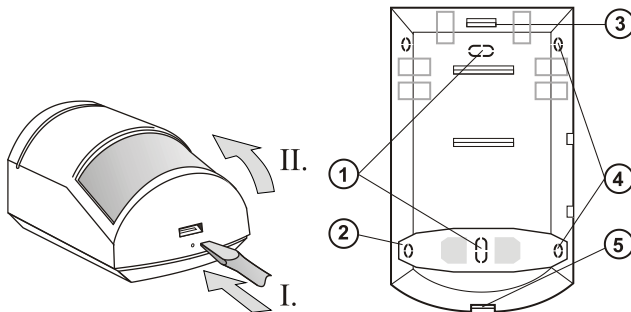

Figure: 1 – holes for installing on a flat wall; 2, 4 – holes for installing in a corner; 3 – PCB tab; 5 – cover tab

1. **Open the detector cover** (by pushing the tab - 5). Avoid touching the PIR sensor inside (11) – you could damage it.
2. **Take out the PCB** – it is held by tab 3
3. **Punch through the holes for the screws and the cable in the plastic base.** The recommended detector installation height is 2.5 m above the floor.
4. **Insert the bus cable and attach the plastic base to the wall using screws** (vertically, with the cover tab facing downwards).



When connecting the detector to the system bus, always switch the power off.

5. **Insert the PCB back** and connect the bus cables to the terminals (8).

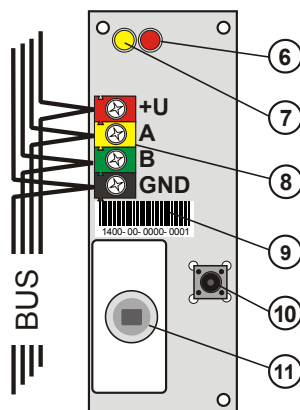

Figure: 6 – red detector activation indicator; 7 – yellow fault indicator; 8 – digital bus terminals; 9 – production code; 10 – tamper contact; 11 – PIR sensor;

6. Proceed according to the control panel installation manual.
Basic procedure:
 - a. When the device is switched on, the yellow LED (7) starts flashing repeatedly to indicate that the module has not been enrolled into the system.
 - b. Go to the **F-Link** program, select the required position in the **Devices** window and launch the enrollment mode by clicking on **Enroll** option.
 - c. Press the tamper contact in the detector (10) – the detector is thus enrolled and the yellow LED indicator goes off.
7. Close the detector cover. In order to comply with the norms, the cover must be secured with the supplied screw.

Detector internal settings

The detector properties can be set in the **Devices** window of the F-Link program. When at the detector position, use the **Internal settings** option to open a dialog window where you can set:

Immunity level: Defines false alarm immunity. The *Standard* level (default setting) combines basic immunity with a rapid reaction. The *Increased* level provides higher immunity but the detector reaction is slower.

LED movement indication: Allows the user to disable movement indication with a red LED.

Detection characteristics

The standard lens that is supplied with the JA-110P detector covers an area of 110 degrees/12 m. The area is covered by 3 beams – see the following figure.

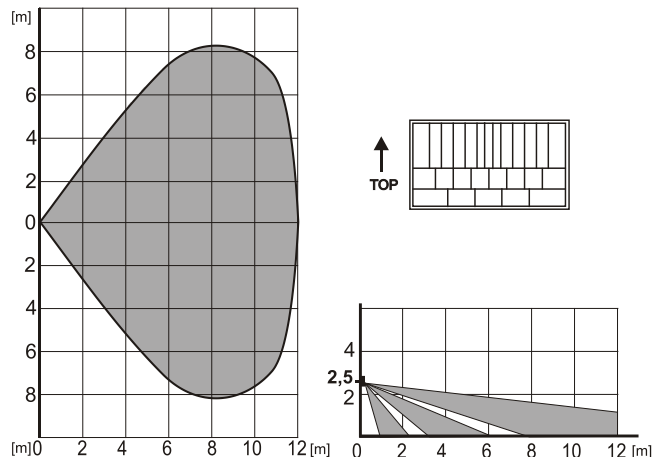

This detection characteristic is valid for standard PIR immunity.

The properties can be changed by using an alternative lens:

JS-7904	designed for long corridors – with a working range of up to 20 m Increased immunity cannot be used with this lens!
JS-7910	equipped only with the upper beam covering 120 degrees/12 m and not covering the floor (can eliminate the movement of small pets on the floor)
JS-7902	vertical curtain – it does not cover an area but creates a detection wall (can be used to create a barrier and report its breach)

Note: when a lens is replaced with a different type, test whether the detector covers the area correctly (wrongly installed lens can cause detection errors).

Technical specifications

Power	from the control panel bus 12 V DC (9 ... 15 V)
Current consumption in standby mode	5 mA
Current consumption for cable choice (maximal)	10 mA
Recommended installation height	2.5 m above the floor
Detection angle / detection coverage	110 degrees/12 m (with standard lens)
Dimensions	60 x 95 x 55 mm
Weight	75 g
Classification	Security grade 2 / Environmental class II (according to EN 50131-1)
Operational environment	Indoor general
Operating temperature range	-10 °C to +40 °C
Average operating humidity	75 % RH, without condensation
Certification body	Trezor Test s.r.o. (no. 3025), Telefication B.V.
Complies with	EN 50131-1, EN 50131-2-2, EN 50130-4, EN 55032, EN 50581, T 031



JABLOTRON ALARMS a.s. hereby declares that the JA-110P product is in a compliance with the relevant Union harmonisation legislation: Directives No: 2014/30/EU, 2011/65/EU if it is used as intended. The original of the conformity assessment can be found at www.jablotron.com - Section Downloads.

Note: Although this product does not contain any harmful materials we suggest you return the product to the dealer or directly to the producer after use.