

The JA-180PB wireless PIR motion/glass-break detector

The JA-180PB is a component of Jablotron's alarm system. It consists of two independent detectors which occupy two separate enrollment addresses in the control panel. The motion detector uses a PIR sensor. The glass-break detector uses the analysis of air pressure variations combined with the characteristic sound of glass breaking. The product is designed for internal use in buildings. The battery-powered detector communicates via Jablotron radio protocol.

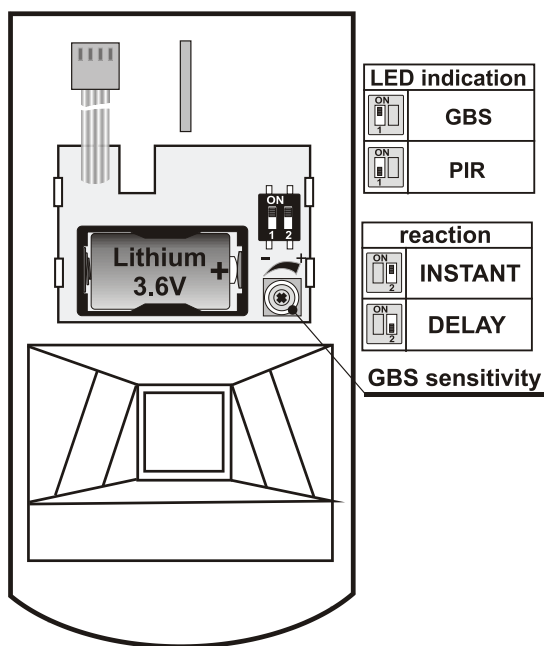
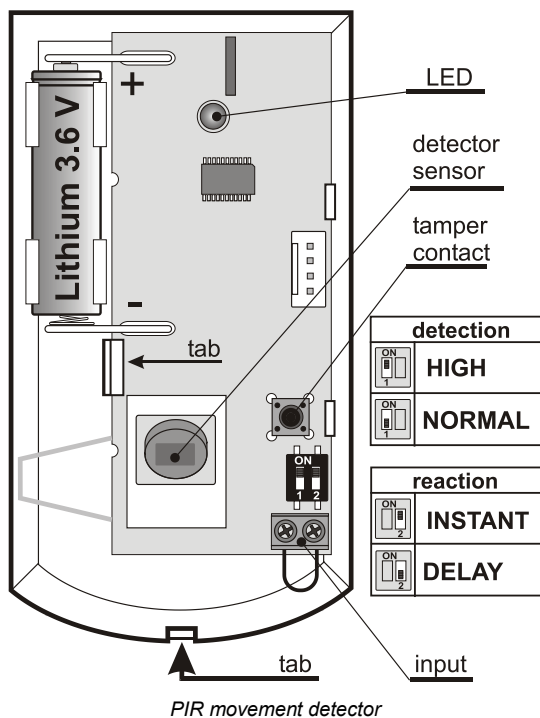

Installation

Installation shall only be undertaken by technicians holding a certificate issued by an authorized distributor. The detector can be installed on a flat wall or in the corner of a room. Within the detection range of the PIR sensor avoid the presence of objects rapidly changing in temperature, such as electrical heaters, gas appliances etc. Moving objects with a temperature close to that of humans such as curtains moving above a radiator, and pets should also be avoided. Detectors should not face windows or spotlights or be near fast-moving air e.g. near ventilation fans or open windows or doors. Because of its sensitivity to air pressure changes and sounds it should not be located close to air conditioning or ventilation outlets. There should be no sources of vibration or audible sounds in the protected area. There should also be no obstacles blocking

the detector's "view" of the protected area. Keep the detector away from metal objects which could interfere with radio communication.

Warning: The most frequent cause of false alarms is bad detector-positioning

Do not arm this detector if there are any people or pets moving within the protected area.

1. **Open the detector cover** by pressing the tab and disconnect the cable to the module located in the front cover.
2. **Remove the internal PIR module** held by an internal tab.
3. **Punch screw holes through the rear plastic cover.** At least one screw should penetrate the tamper-sensitive section.
4. **Screw the rear cover to the wall,** about 2 metres above the floor (vertically, with the tab down).
5. **Return the PIR module** to its original place.
6. **Leave the cover open** and then follow the control panel or receiver manual. The basics of enrollment are:
 - a. Enter enrollment mode on the control panel by keying in "1" in Service mode.
 - b. Install a battery in the PIR detector to activate its enrollment.
 - c. Install a battery in the glass-break detector and then connect its cable to the PIR module. This will activate its enrollment to the next vacant address in the control panel. This means that the glass-break detector enrolls after the PIR does.
 - d. Exit enrollment mode by pressing "#"

To observe EN 50131-2-2 the tab must be secured by the supplied screw.

To enroll a detector after having already connected batteries, first disconnect the batteries, and press and release the tamper sensor to discharge any remaining charge to ready the device for enrollment. After installing batteries into the detector, allow two minutes for stabilisation. During this period the LED is continuously lit.

PIR module DIP switches

NORM / HIGH: selection of immunity to false alarms. The NORM position combines very good immunity with fast sensor reactions. The HIGH position gives increased immunity with a slower reaction time and is only used for problematic installations.

INS / DEL. DEL provides entrance & exit delays for detectors installed in a building entrance. INS allows the detector to instantly trigger alarm activation if the control panel is armed. This DIP switch (INS/DEL) only has an effect if the detector has a **natural reaction** assigned to its address in the Jablotron control panel. It also has no effect when used with a JA-182N or JA-180N receiver.

Glass-break module DIP switches

DEL / INS selects the **reaction of the control panel** if glass-breaking is detected. DEL provides entrance & exit delays and is recommended for detectors installed near a building's entrance door. INS allows the detector to instantly trigger alarm activation if the control panel is armed. This DIP switch (INS/DEL) only has an effect if the detector has a **natural reaction** assigned to its address in the Jablotron control panel. It also has no effect when used with a JA-182N or JA-180N receiver.

PIR / GBS: This selects whether PIR or glass-break triggering is shown by the LED. Changing this setting only has an effect during the first 15 minutes after closing the cover (test mode).

Note: Although both detectors are located in one housing, they do act independently. Each one has its own address. Each one also has its own selectable reaction via DIP switches in the detector or in SERVICE mode on the control panel.

Testing the detector

15 minutes after closing the detector cover, the LED shows PIR or glass-beak detector triggering according to what was previously selected by the PIR/GBS DIP switch during test mode. The strength and quality of detector signals can be measured by the control panel in Service mode.

With the DIP switch in **position PIR**, short LED flashes indicate the processing of movement triggering the detector. Long flashes show that movement detection is being signalled to the control panel.

With the DIP switch in **position GBS**, the LED flashes very briefly when air pressure changes occur, e.g. a soft knock on a window. A long flash indicates triggering by breaking glass and the transmission of a signal to the control panel.

Testing and adjusting the glass-break sensor:

- Using a suitable tool or a hand protected by gloves, one by one, knock all the windows that should be under the detector's protection. A visible deformation of the glass should occur but without any damage.
- The deformation of glass causes a change in the air pressure of the room which makes the LED on the detector flash quickly. The DIP switch must be in the GBS position.
- Sensitivity to air pressure changes can be adjusted by a potentiometer on the glass-break sensor PCB located inside the front cover of the detector. Turning clockwise increases

sensitivity. Avoid selecting too high a sensitivity as this can cause a short battery lifetime.

- The complete function of the glass-break detector can be tested with a GBT-212 glass-break simulator. After knocking the glass, this simulator will automatically generate the characteristic sound of breaking glass to create the conditions for detector triggering.
- If there are any devices in the detector's protected area generating sound such as air conditioning, heating, fax machines, refrigerators, etc., check that they are not triggering alarms by emitting sounds like breaking glass.

Detection characteristics of the PIR sensor

The default lens supplied covers an angle of 120° and a distance of 12 metres. The area is covered by three beams as shown in the following picture.

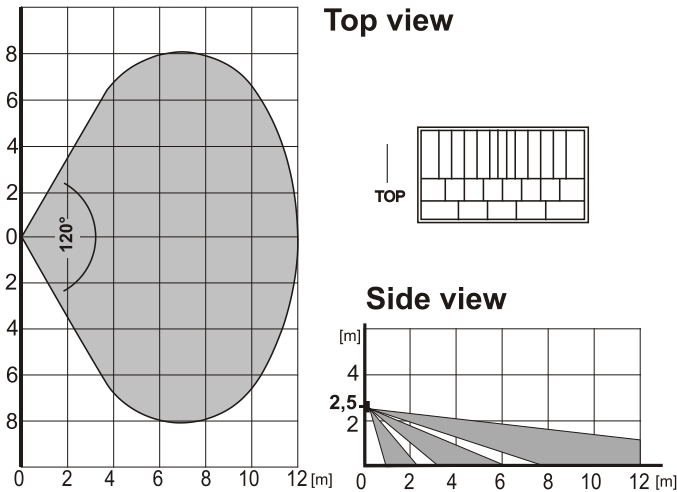

The characteristics can be changed by using optional lenses:

JS-7904	Suitable for long corridors. The middle beam covers 20 meters.
JS-7910	Only employs an upper beam with a 120° angle and a 12 metre range. Ignoring the floor eliminates the effect of the movement of small pets.
JS-7902	Has a vertical beam forming a wall-like detection barrier which triggers the detector if someone walks through it.

Note: After changing the lens, test that the desired area is protected. Incorrect installation of the lens can disable detection.

5 minute/1 minute PIR sensor sleep time

To save battery energy, the PIR sensor part of the detector switches to battery-save mode 15 minutes after the cover is closed. During battery-save mode the PIR sensor still always watches out for movement. The first movement detected is then signalled to the control panel instantly, and for the next **5 minutes the PIR sensor ignores any further movement**. After these 5 minutes, the PIR sensor then returns to watching out for movement until re-triggered. The sleep time can be shortened to 1 minute by pressing the tamper switch during battery installation. Not pressing the tamper switch gives a sleep time of 5 minutes. This sleep time has no effect on the glass-break sensor which is always ready to trigger a glass-break alarm.

Auxiliary alarm input

There is an input terminal in the detector which, among other things, can be used to detect open doors or windows.

Open circuiting the input has the **same effect as movement** in front of the detector

The maximum allowable cable length to connect a normally closed sensor to the terminal is 3 metres. Short circuit these terminals if the input is not used.

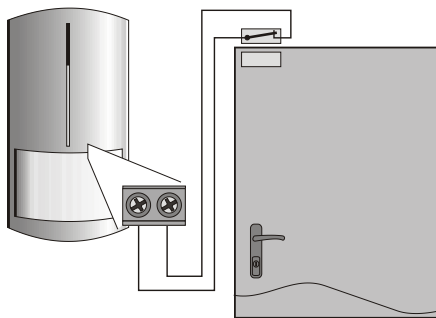

Detection characteristics of the glass-break sensor

The directional response of the glass-break sensor has near spherical characteristic and it is possible to detect breaking glass up to 9 metres away as can be seen in the below diagram. The size of glass should be at least 60 by 60 cm. For smaller sizes the detection range can be shorter. Only breaking glass forming part of the walls

within the protected area can be detected. All kinds of glass can be protected including windows covered with unbreakable folio.

Warning: This type of detector is not suited to sensing holes being cut through glass by glass cutters. For this reason, valuables near windows should be covered by PIR sensors.

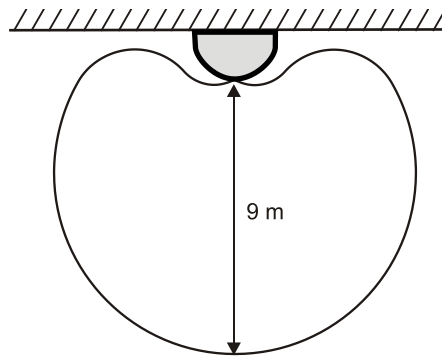

Glass-break detector relative directional sensitivity

Battery replacement

This detector has two batteries inside whose condition is regularly checked. If any of the batteries has expired, then the user or installer is informed. The detector continues to work and each movement in front of the detector is shown by a brief LED flash. The batteries should be replaced within two weeks by a qualified technician in SERVICE mode.

After battery replacement the detector needs two minutes to stabilise during which the LED is permanently lit. After battery replacement, test the functioning of both sensors. Expired batteries should not be thrown into the garbage but disposed of according to local regulations.

Removing the detector from the system

If a detector is removed, the control panel announces the removal. The detector has to be deleted from its two addresses in the control panel before intentional removal.

Technical parameters

Voltage of PIR sensor: Lithium battery type
CR14500 (AA) 3.6 V/2.45 Ah

Voltage of GBS sensor: Lithium battery type
CR14250 (1/2AA) 3.6 V/1.2 Ah

Please note: Batteries are not included

Typical battery lifetime approx. 3 years (PIR sensor sleep time 5 min.)

Communication band: 868.1 MHz, Jablotron protocol

Communication range: approx. 300 m (open area)

Recommended installation height: 2–2.5 m above floor level

PIR sensor detection angle/detection range:

120°/12 m (with basic lens)

Glass-break detection range 9 m (glass min. 60 x 60 cm)

Operational environment according to EN 50131-1 II. Indoor general

Operational temperature range -10 °C to +40 °C

EN 50131-1, EN 50131-2-2, EN 50131-2-7-1, EN 50131-5-3

classification: grade 2

Dimensions, weight 110 x 60 x 55 mm, 120 g

Complies with ETSI EN 300 220, EN 50130-4, EN 55022, EN 60950-1

Can be operated according to ERC REC 70-03



JABLOTRON ALARMS a.s. hereby declares that the JA-180PB is in a compliance with the relevant Union harmonisation legislation: Directives No: 2014/53/EU, 2014/35/EU, 2014/30/EU, 2011/65/EU. The original of the conformity assessment can be found at www.jablotron.com - Section Downloads.



Note: Disposing of this product correctly will help save valuable resources and prevent any potential negative effects on human health and the environment, which could otherwise arise from inappropriate waste handling. Please return the product to the dealer or contact your local authority for further details of your nearest designated collection point.

