

The JA-150G-CO wireless interface for carbon monoxide detectors Ei208(D)W

The JA-150G-CO is a plug-in module that can be connected directly to the Ei208W/Ei208DW stand-alone carbon monoxide detectors and will allow wireless connection to the JABLOTRON system. It provides information about alarm activation or deactivation, low battery and lost communication status.

The module occupies one position in the system and should be installed by a trained technician with a valid certificate issued by an authorised distributor.

Installation

Select an appropriate installation place considering the Ei208(D)W detector installation manual

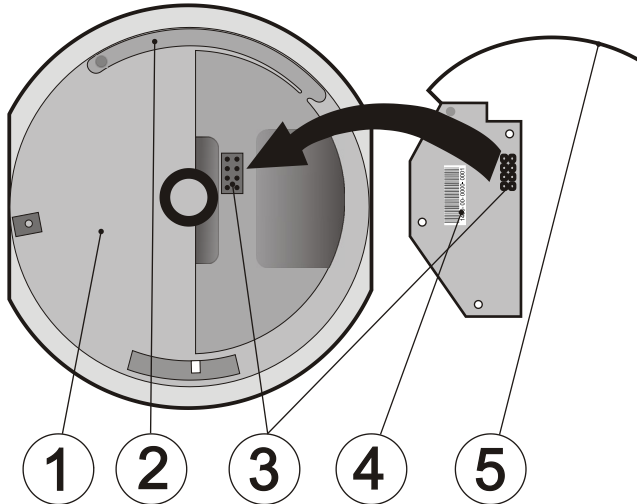

Figure: 1 – Ei208(D)W detector, 2 – space for antenna, 3 – connector to plug-in an Ei208(D)W, 4 – production code, 5 – antenna

Installation procedure:

1. Open the detector by turning anti-clockwise against the mounting base
2. Plug the JA-150G-CO module into the detector's connector (3). Pay attention to correct placing of the antenna (5) onto the correct place (2) when plugging in.
3. Proceed according to the control panel installation manual.

Basic procedure:

- a. There must be a JA-11xR radio module installed in the control panel.
- b. Go to **F-Link** and select the required position in the **Devices** window and launch the enrollment mode by clicking on the **Enroll** option.
- c. By closing (turning ON) the detector with the plug-in module inside, the enrollment signal is transmitted – the module is thus enrolled to the control panel. The enrollment signal is also transmitted when the module is plugged in to the detector system connector.

Note: Enrolling the module to the system is also possible by entering the production code (4) via F-Link software. All digits in the production code are required (1400-00-0000-0001). The production code can be found on the sticker under the bar code, glued on the PCB of the module.

To perform testing and normal operation see the Ei208(D)W detector installation manual.

Technical specifications

Power	from Ei208(D)W battery
Communication frequency	868.1 MHz, Jablotron protocol
Maximum radio-frequency power (ERP)	6 mW
RF range	approx. 300 m (open area)
Dimensions	109 x 24 x 22 mm
Environmental class	II. Indoor general (acc. EN 50131-1)
Operational temperature range	-10 °C to +40 °C
Comply with	ETSI EN 300 220-1, EN 50130-4 EN 55022, EN 60950-1, EN 50581 ERC REC 70-3
Operational conditions	



JABLOTRON ALARMS a.s. hereby declares that the JA-150G-CO is in a compliance with the relevant Union harmonisation legislation: Directives No: 2014/53/EU, 2014/35/EU, 2014/30/EU, 2011/65/EU. The original of the conformity assessment can be found at www.jablotron.com - Section Downloads.



Note: Disposing of this product correctly will help save valuable resources and prevent any potential negative effects on human health and the environment, which could otherwise arise from inappropriate waste handling. Please return the product to the dealer or contact your local authority for further details of your nearest designated collection point.

